



# Extension Module, 2 and 4 Channel Revision A



© 2019 ITERIS, INC.

All rights reserved. No parts of this work may be reproduced in any form or by any means - graphic, electronic, or mechanical, including photocopying, recording, taping, or information storage and retrieval systems - without the prior written permission of Iteris, Inc.

Products that are referred to in this document may be either trademarks and/or registered trademarks of the respective owners. The publisher and the author make no claim to these trademarks.

While every precaution has been taken in the preparation of this document, the publisher and the author assume no responsibility for errors or omissions, or for damages resulting from the use of information contained in this document or from the use of programs and source code that may accompany it. In no event shall the publisher and the author be liable for any loss of profit or any other commercial damage caused or alleged to have been caused directly or indirectly by this document.

The information contained in this document is subject to change without notice.

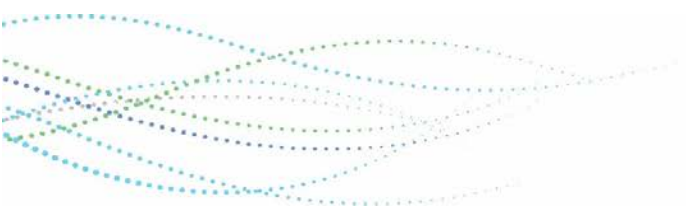

## TABLE OF CONTENTS

1.	INTRODUCTION .....	4
2.	SETUP AND INSTALLATION.....	5
3.	CONFIGURATION SWITCH SETTINGS .....	8
3.1	Switch 3 – TS-1 Backplane Outputs.....	8
3.2	Switch 4 - Front Panel Bike Indicator Outputs .....	9
3.3	Switch 5 – Delay/Extend and TS-2 Communications.....	9
3.4	Switch 6 - EM Bus Backplane Communication .....	10
3.5	Switch 7 – Production Configuration.....	10
3.6	Jumper 6 – Chassis Ground .....	10
4.	PRODUCT SUPPORT .....	11

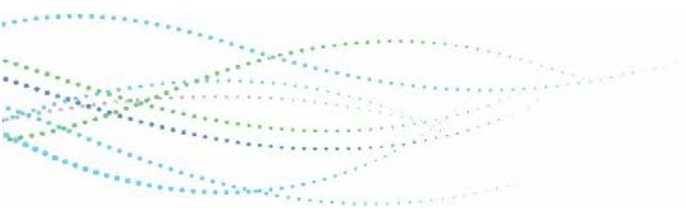

## 1. INTRODUCTION



**Two and Four Channel Extension Modules**

The Vantage EM-2 and EM-4 Extension Modules are designed to provide enhanced extension module input and output capability to the Vantage Edge2, Next and Radius family of products. The modules provide an additional 2 or 4 optically isolated outputs. The modules can be used in either NEMA TS-1, TS-2, or CalTrans 170 / 2070 type cabinets and can be seamlessly inter-mixed with existing Vantage expansion modules.

### Features

- Seven segment LED display for unit address.
- RJ-45 extension module interface.
- 2 or 4 external optically isolated outputs from a faceplate mounted 3 or 5 pin terminal block.
- New firmware input diagnostics.
- 2 or 4 high intensity LED output / input indicators.
- +12 or +24 volt DC operation.
- NEMA TS-1, TS-2, and CalTrans 170 / 2070 compatible.

## 2. SETUP AND INSTALLATION

 **Note:** Refer to [Section 3: Configuration Switch Settings](#) before installing the Extension Module into the rack.

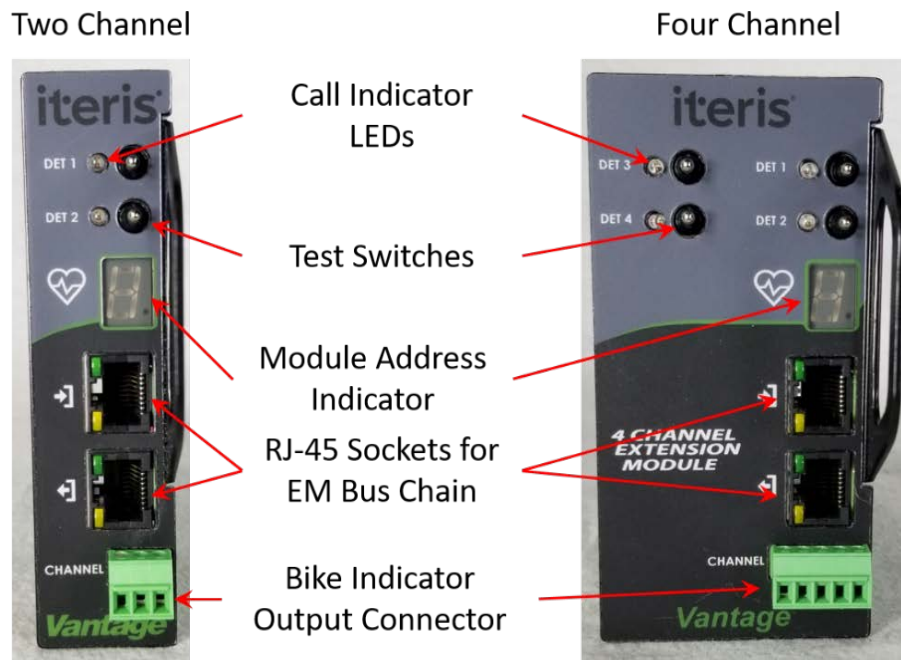

Vantage Extension Modules can be used to provide additional output capability to Edge2 processor modules, Next or Radius CCUs. The Extension Modules are available with two or four channels.

 **CAUTION!** Always use an ESD wrist strap or other precaution to prevent electrostatic discharge damage to the Vantage modules.

The Extension Modules are connected to the Edge2 processor module, Next or Radius CCU using a standard CAT5 cable. The Extension Module cable plugs into the EM-BUS RJ-45 port. The other end plugs into the Extension Module RJ-5 "Input" port. Additional modules can be chained together going from Extension Module "Output" port to Extension Module "Input" port. Each Edge2 processor, Next or Radius CCU can support up to sixteen Edge2 Extension Modules. The Extension Modules automatically increment their address as the chain is expanded. Addresses range from "0" to "F", providing up to 16 unique addresses (0 - 9 and A - F).

### Typical extension module output designators

EM-0:1 This is channel one on the first Extension Module of the device chain.

EM-0:2 This is channel two on the first Extension Module of the device chain.

EM-1:3 This is channel three on the second Extension Module of the device chain.

We also know that this Extension Module is a four channel type because of the use of channel three. A two channel extension module would only have two channels.

### Jacks and Plugs

RJ-45 EXTENSION MODULE Port - this port is used to chain additional Vantage modules to your system. There is a green and a yellow LED on the RJ-45 system EM-BUS jack. The green LED is always "ON", the yellow LED blinks until an Extension Module is connected.

### LED Indicators

OUTPUT CHANNEL LEDs - these two or four red LEDs correspond to the two or four output channels on each Extension Module. When the output channel LED is active (ON), the associated red LED will illuminate.

INPUT / OUTPUT RJ-45 JACK LEDs - there is a green and a yellow LED on the RJ-45 extension module jack. The green LED is always ON, the yellow LED is on solid unless it is the last module in the Edge2 chain. If it is the last module in the Edge2 module chain, the yellow LED blinks. This assumes that all modules in the chain are properly initialized. Uninitialized modules show a " - " in the seven segment numeric display window.

***⚠ Important:*** *Proper Extension Module Termination.*

*When an Extension module is properly terminated and recognized as part of the system chain, an address from "0" to "F" will be displayed in the seven segment numeric display. If it is the last module in the chain, the yellow led on the RJ-45 connector should blink and a "." (dot) will appear after the address character. If this is not the case, then try unplugging the system to force it to reinitialize and re-query all the devices on the device chain. If a device on the system is not initialized correctly, it will not show up as a valid selection under the system Channel Out (Ch/Out) menu item selection.*

MODULE ADDRESS INDICATOR - this display shows the address of the Extension Module in the system chain. Addresses range from "0" to "F" (0 - 9 and A- F).

### Switches

TEST SWITCHES - these switches allow the output channels to be manually activated by using any one of the two or four test switches. The "Test Switch" has three positions:

Down = Constant Call, Middle = Normal Operation, and Up = Momentary Call.

### Extension Module Output Channel Assignment

When an extension module is connected to an Edge2 processor additional outputs are available for assignment. The output channel number on the Edge2 processor will display a string similar to the one in the figure below.

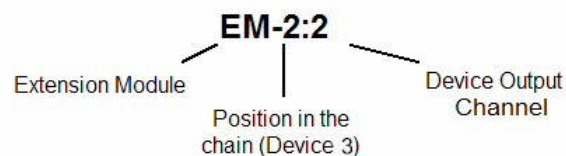

In this example the Extension module would most likely be a two channel extension module, it is the third device in the chain, and the output is assigned to the second of the two channels.

## Front Panel Connector Outputs

This module can output detections via the pluggable connector on the front panel. This can be used to drive the Iteris Bike Indicator or used for other applications. Connect the wires from the Extension Module to the Bike Indicator panel as shown.

Position	Function
1	LOGIC GROUND
2	CH1 OUTPUT
3	CH2 OUTPUT
4	CH3 OUTPUT (4 CHANNEL ONLY)
5	CH4 OUTPUT (4 CHANNEL ONLY)

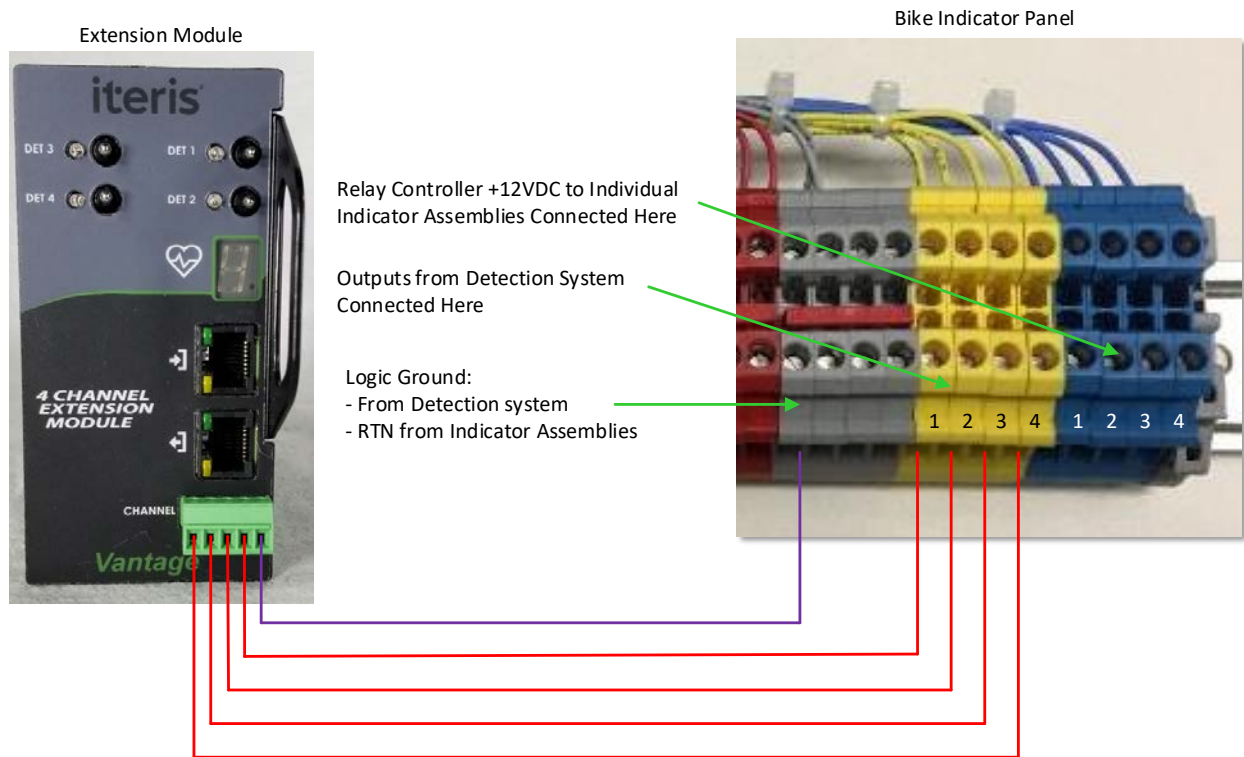



## 3. CONFIGURATION SWITCH SETTINGS

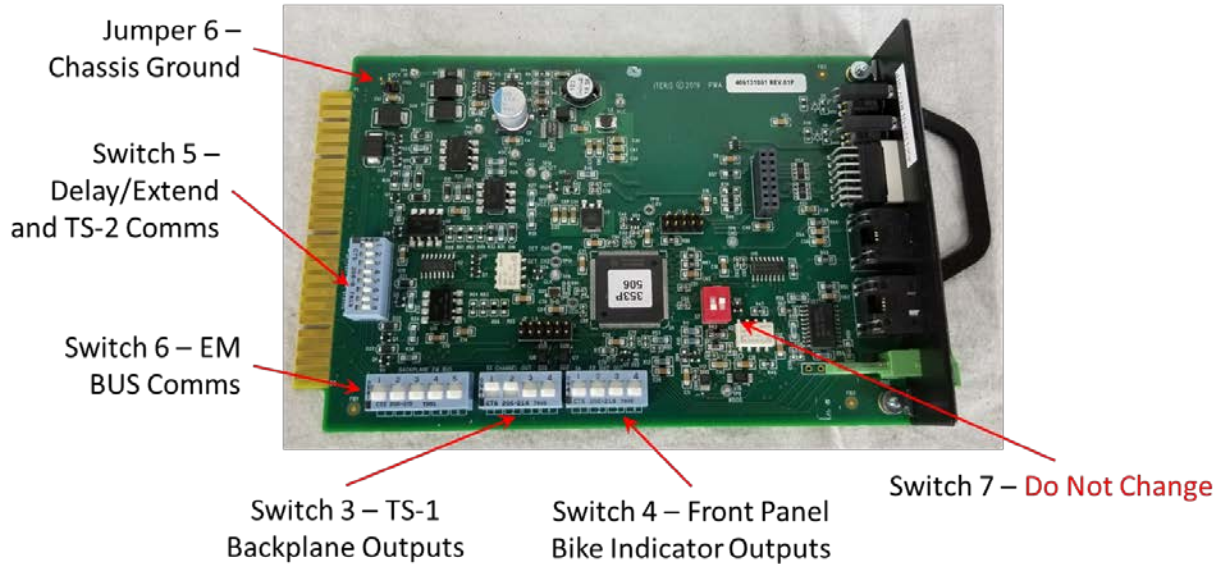

### 3.1 Switch 3 – TS-1 Backplane Outputs

Switch S <sub>3</sub>	Switch Setting	Function
1	Up (Default) Down	CH1 Output enabled CH1 Output disabled
2	Up (Default) Down	CH2 Output enabled CH2 Output disabled
3	Up (Default) Down	CH3 Output enabled CH3 Output disabled (4 CHANNEL ONLY)
4	Up (Default) Down	CH4 Output enabled CH4 Output disabled (4 CHANNEL ONLY)



### 3.2 Switch 4 - Front Panel Bike Indicator Outputs

Switch S <sub>4</sub>	Switch Setting	Function
1	Up (Default) Down	CH1 Bike Output Enabled CH1 Bike Disabled
2	Up (Default) Down	CH2 Bike Output Enabled CH2 Bike Disabled
3	Up (Default) Down	CH3 Bike Output Enabled CH3 Bike Disabled (4 CHANNEL ONLY)
4	Up (Default) Down	CH4 Bike Output Enabled CH4 Bike Disabled (4 CHANNEL ONLY)

### 3.3 Switch 5 – Delay/Extend and TS-2 Communications

#### Delay/Extend

The Edge2 processor can be configured to receive Green Inputs to adjust the timing of detection zones or to control if a count zone is active or inactive.

**Note:** Green inputs come into the Extension Module on pins 1,2,3 and 10.

#### TS-2 Communication

The Edge2 can be configured to communicate in a TS-2 detector rack.

If all four DIP switches are "ON" (Up), configuration is set for NEMA TS-2 applications. If all four DIP switches are "OFF" (Down), configuration is set for 170 / 332 or NEMA TS-1 applications.

All four DIP switches are "ON" for most applications (TS-1 operation). Some special applications may require a change to these settings. The default position for these four DIP switches is in the "ON" position.

Switch S <sub>5</sub> Position	Switch Setting	Function
1	Up (Default) Down	On = Green IN 1 Off
2	Up (Default) Down	On = Green IN 2 Off
3	Up (Default) Down	On = Green IN 3 Off
4	Up (Default) Down	On = Green IN 4 Off
5	Up (Default) Down	On = Status Bit 1 Enabled Off = Status Bit 1 Disabled

Switch S <sub>5</sub> Position	Switch Setting	Function
6	Up (Default) Down	On = Status Bit 2 Enabled Off = Status Bit 2 Disabled
7	Up (Default) Down	On = Status Bit 3 Enabled Off = Status Bit 3 Disabled (4 CHANNEL ONLY)
8	Up (Default) Down	On = Status Bit 4 Enabled Off = Status Bit 4 Disabled (4 CHANNEL ONLY)

### 3.4 Switch 6 - EM Bus Backplane Communication

The Edge2 extension modules can be configured to communicate directly through the backplane of the V2 rack, eliminating the need for extension module cables.

Switch S <sub>6</sub> Position	Switch Setting	Function
1	Up Down(default)	Backplane Cable
2	Up Down(default)	Backplane Cable
3	Up Down(default)	Backplane Cable
4	Up Down(default)	Backplane Cable
5	Up Down(default)	Backplane Cable

### 3.5 Switch 7 – Production Configuration

Switch 7 is a two position switch used for production configuration and should not be changed in the field.

### 3.6 Jumper 6 – Chassis Ground

Jumper 6 ties logic and chassis ground together on the Extension Module. This setting should only be used when advised by Iteris Product Support.

## 4. PRODUCT SUPPORT

### Product Support Team

The Iteris<sup>®</sup> Product Support Team consists of a group of highly skilled individuals that are knowledgeable and readily available to answer your questions or assist you with any of our Vantage products. Please do not hesitate to contact us at:

 Toll free: (888) 254-5487

For more information on Iteris, as well as the products and services that we provide, visit our website at:

 [www.iteris.com](http://www.iteris.com)

### Iteris Resource Center

This site contains additional training and technical support information covering the whole range of Vantage products. Registration is easy. Visit the address below to register and begin enjoying the benefits immediately.

 [www.iteris.com/support](http://www.iteris.com/support)

The Resource Center app is available from the Apple App Store or the Google Play store.



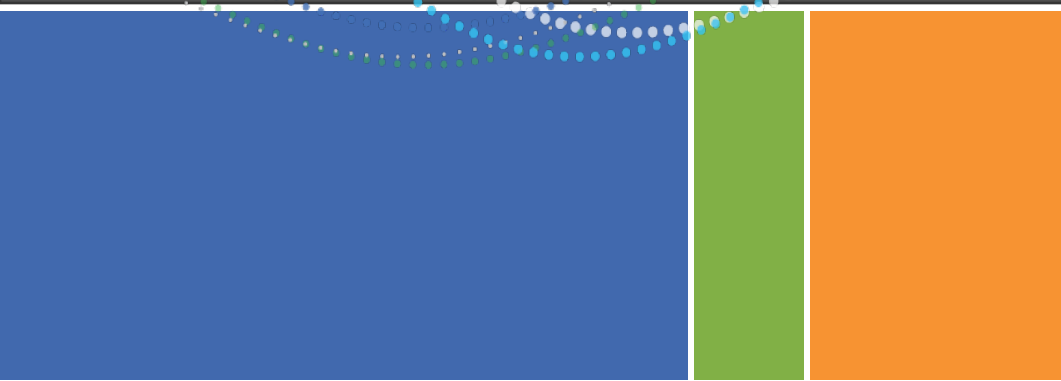
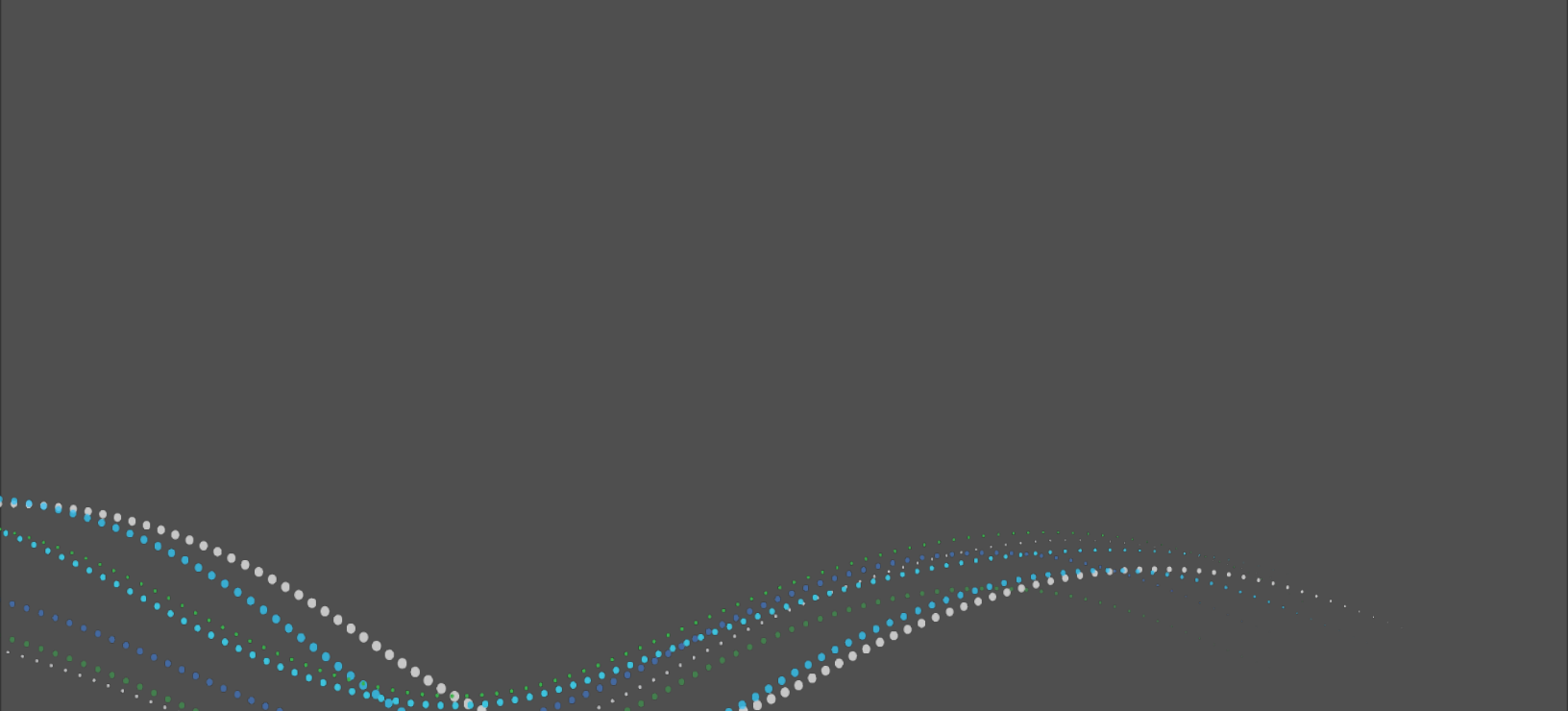

**iteris<sup>®</sup>**

1700 Carnegie Avenue, Suite 100  
Santa Ana, CA 92705

[iteris.com](http://iteris.com)

© 2019 Iteris, Inc. All rights reserved.

Innovating Through Informatics™